

Netzer pin map



Pins of pin header JP1

Name	Description
INT	GPIO pins
CLK	
MI	
MO	
CS	
IO4	
IO5	
IO3	
VA2	Connection for Power-over-Ethernet . That is the center tap of the Ethernet coil between RJ45 pins 3 and 6.
VB2	Connection for Power-over-Ethernet . This pin is directly connected to the network jack of Netzer (RJ45 pins 7 and 8).

Pins of pin header JP2

Name	Description
RST	Use this pin to reset Netzer. The signal is low active (this means 0 resets Netzer). The Reset signal can also be used for waking up Netzer from sleep mode (after shut down). The pin is optional and can be left open.
3V3	Pin for power supply. Minimum voltage is 3.1 V. Maximum voltage is 3.6 V.
GND	Ground potential.

Name	Description
IO0	GPIO pins
IO1	
IO2	
TX	
RX	
VA1	Connection for Power-over-Ethernet . That is the center tap of the ethernet coil between RJ45 pins 1 and 2.
VB1	Connection for Power-over-Ethernet . This pin is directly connected to the network jack of Netzer (RJ45 pins 4 and 5).

Power-over-Ethernet (PoE)

The four connections VA1, VA2, VB1 and VB2 are connections from the network socket where a Power-over-Ethernet supply can be connected to.

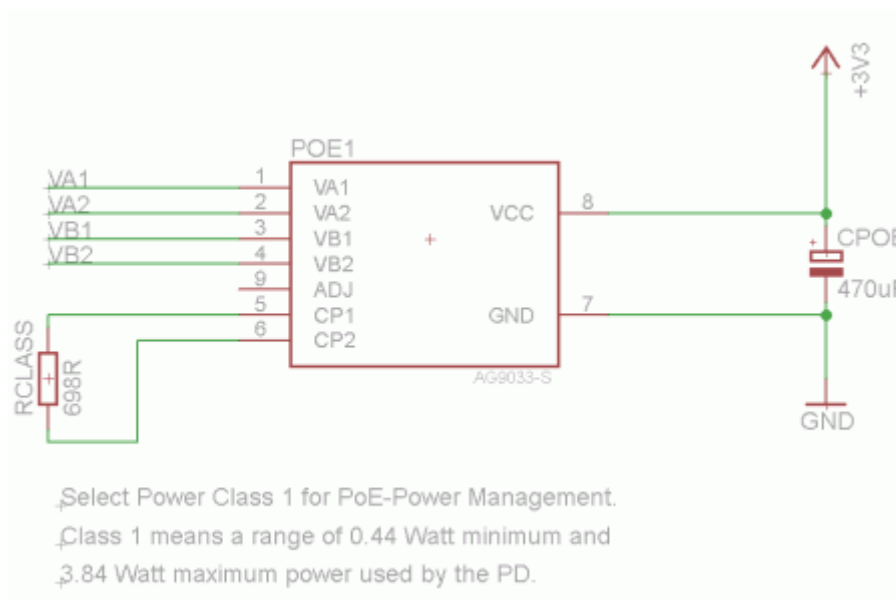

The image shows an example circuit. Here the PoE supply AG9033 of Silver Telecom is used.

Overview over all GPIO signals

Here only some common informations are shown. The implemented functionality of a single IO depends on the single project.

Netzer Name	ID	PIC Pin	Maximum output current	Maximum input voltage	Functionality
SPI_INT	j	RC2	25 mA	5,5 V	Interrupt pin of the SPI slave module, PWM capable
SPI_CLK	k	RC3	25 mA	5,5 V	Clock line of the SPI module or I2C module

Netzer Name	ID	PIC Pin	Maximum output current	Maximum input voltage	Functionality
SPI_MI	l	RC4	25 mA	5,5 V	Data input of the SPI module, data line of the I2C module
SPI_MO	m	RC5	25 mA	5,5 V	Data output of the SPI module
SPI_CS	i	RF7	2 mA	5,5 V	Select input of the SPI slave module
RX	h	RC7	25 mA	5,5 V	UART Receive line
TX	g	RC6	25 mA	5,5 V	UART Send line
IO0	a	RB0	25 mA	5,5 V	Interrupt capable input
IO1	b	RB1	25 mA	5,5 V	Interrupt capable input
IO2	c	RB2	25 mA	5,5 V	Interrupt capable input
IO3	d	RD1	8 mA	5,5 V	PWM capable
IO4	e	RA2	2 mA	3,3 V	ADC capable
IO5	f	RA3	2 mA	3,3 V	ADC capable

From:

<https://www.mobacon.de/dokuwiki/> - **MoBaCon**

Permanent link:

<https://www.mobacon.de/dokuwiki/doku.php?id=en:netzer:pins>

Last update: **2025/06/11 20:42**

