

Impulse handling with Netzer IO

Netzer is able to generate and capture signals at IO3 and SPI_INT.

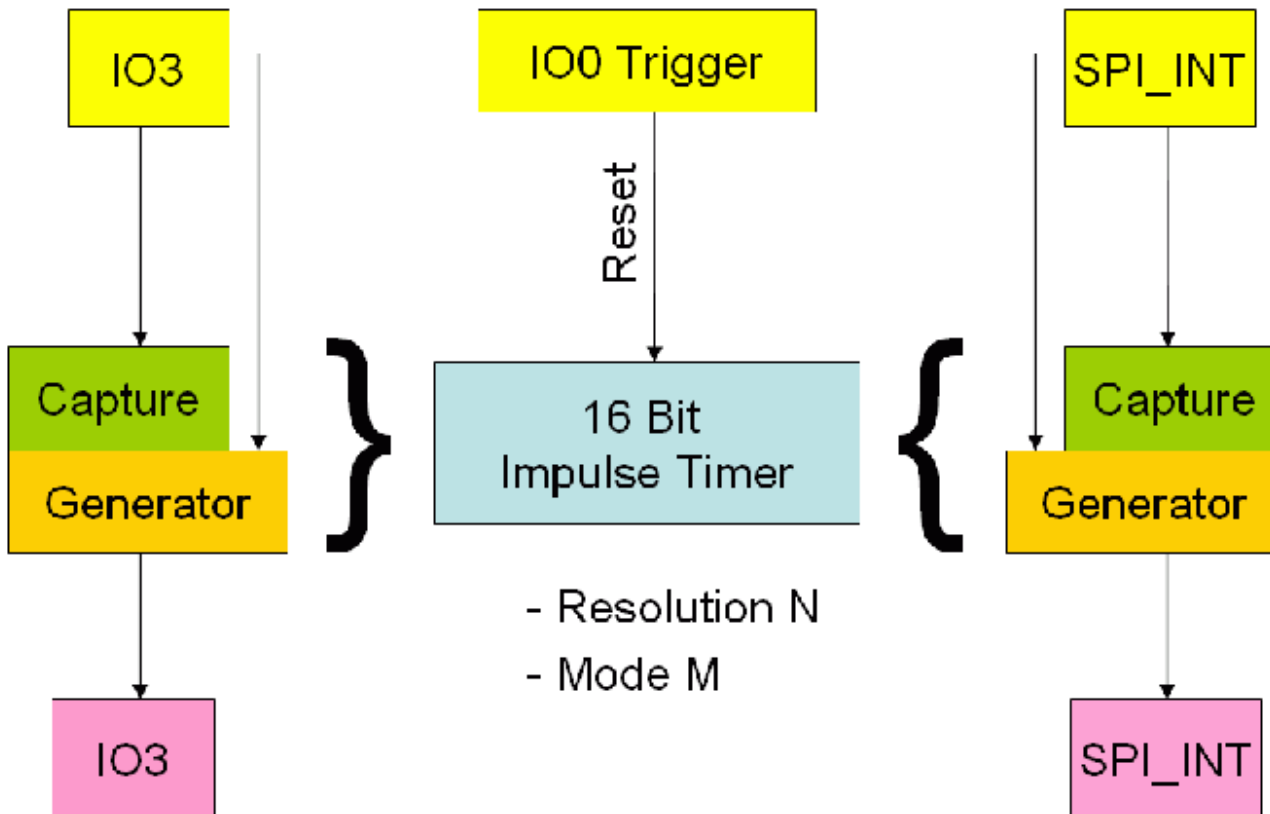

The image shows the structure of the impulse generator/capture.

The impulse module is divided into two modes, the unsynchronized mode and the IO0 synchronized mode. Both, IO3 and SPI_INT, can either work in unsynchronized or in IO0 synchronized mode.

Furthermore a mode M can be configured:

- Continuous mode
- Single
- Triggered by IO0

Resolution N can be either 100ns, 200ns, 400ns or 800ns. All raw values associated with Capture/Generator module must be multiplied by N to get the final time value.

Last but not least channels can be configured for capturing (measuring impulses) or generating impulses.

Examples

Some of the examples below show both signals IO3 and SPI_INT. Of course impulse module can be

configured to use only one of them.

The examples below only show positive logic. Simply invert the signals to get negative logic examples.

In the IO0 examples the IO0 trigger is configured for rising edge. Simply invert the IO0 signal to get falling edge examples.

Generating impulses in continuous mode (Unsynchronized)

The impulse timer is free running in this mode. Changes on IO0 will not reset the impulse timer.

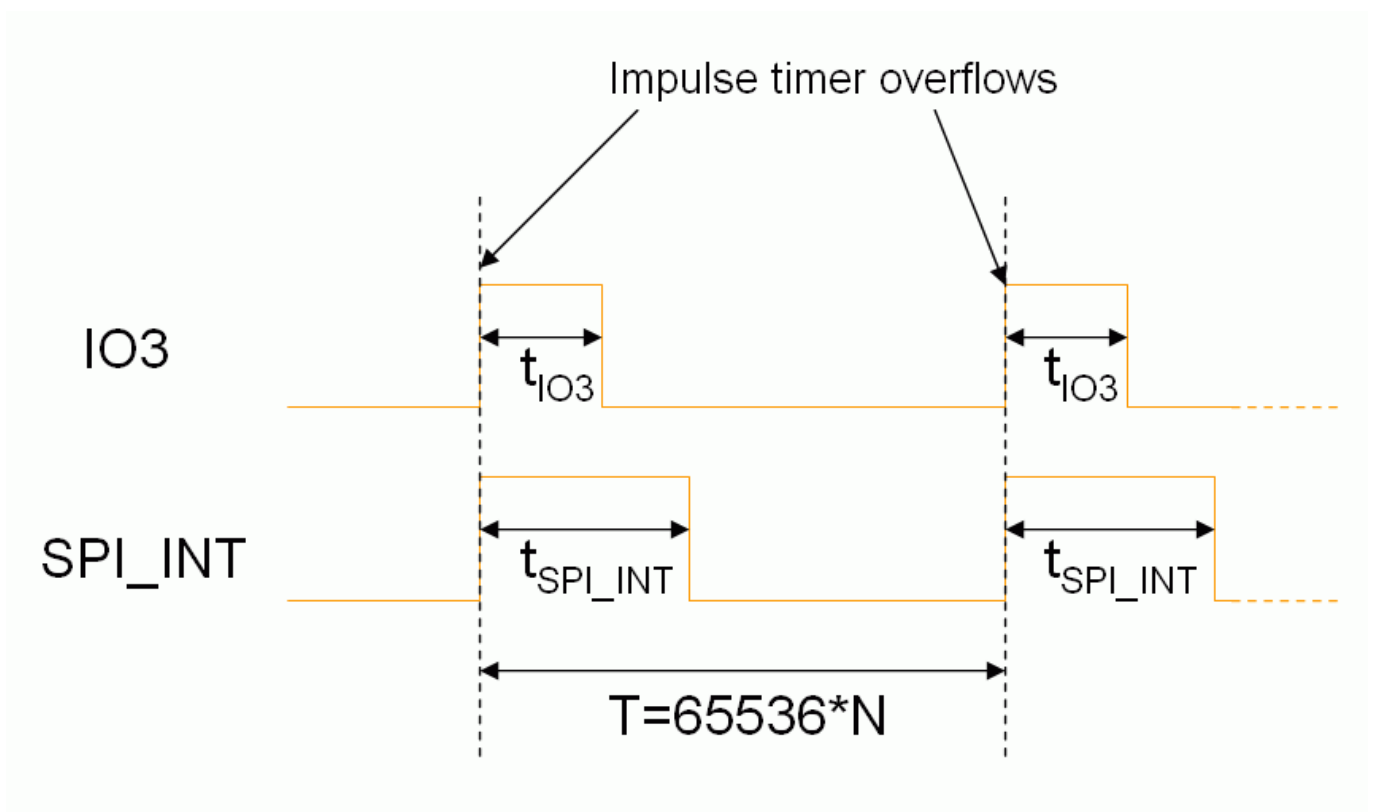

Generating impulses in single mode (Unsynchronized)

The impulse timer is free running in this mode. Changes on IO0 will not reset the impulse timer.

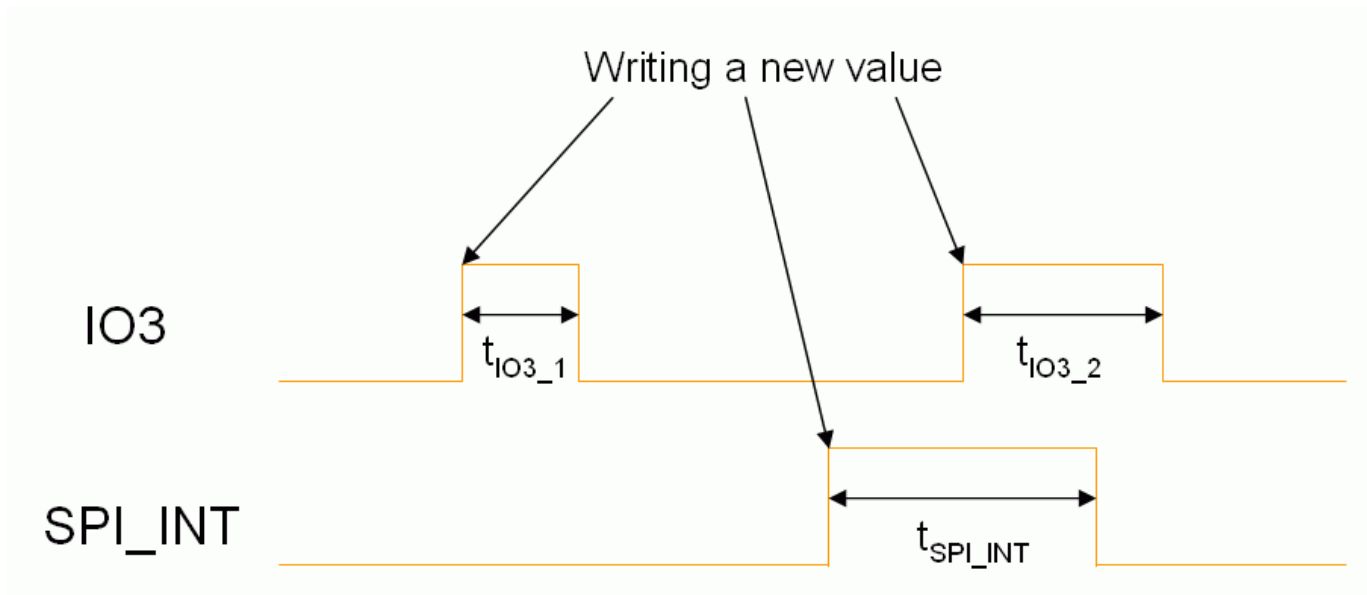

Generating impulses in "Triggered by IO0" mode (Unsynchronized)

This mode shall not be used.

Generating impulses in continuous mode (IO0 synchronized)

This mode shall not be used.

Generating impulses in single mode (IO0 synchronized)

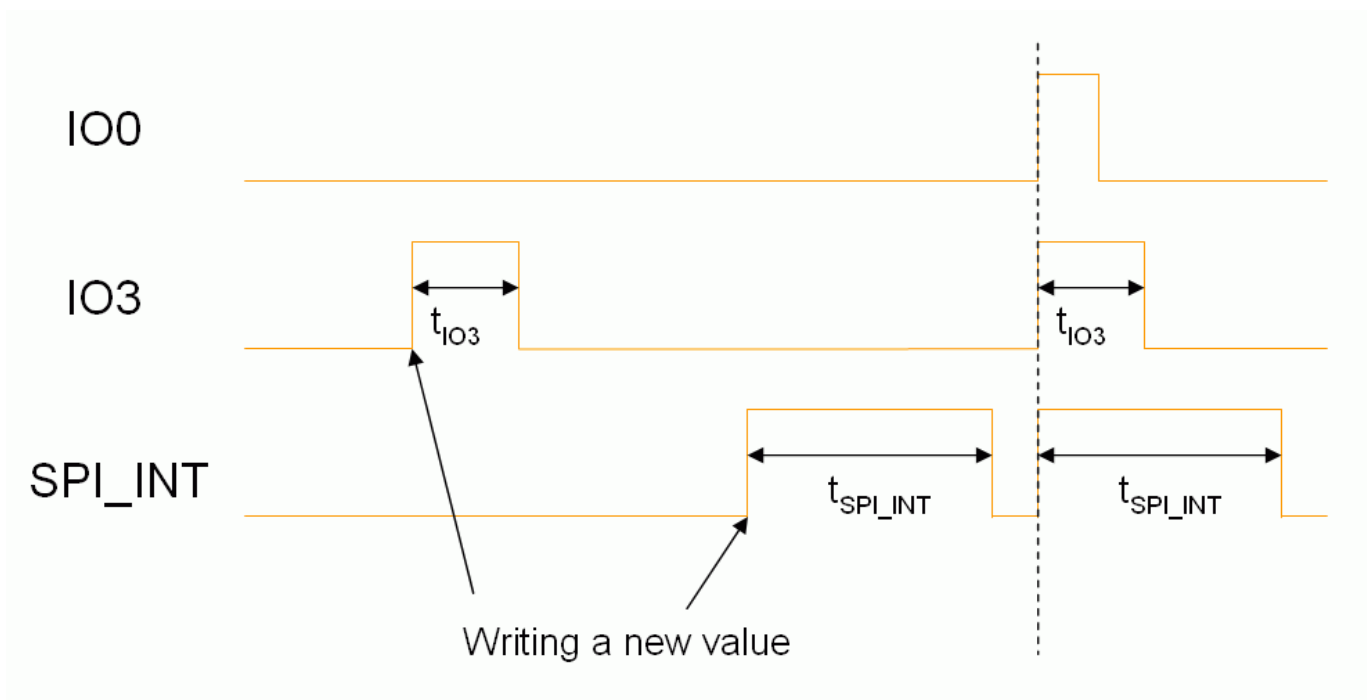

Generating impulses in "Triggered by IO0" mode (IO0 synchronized)

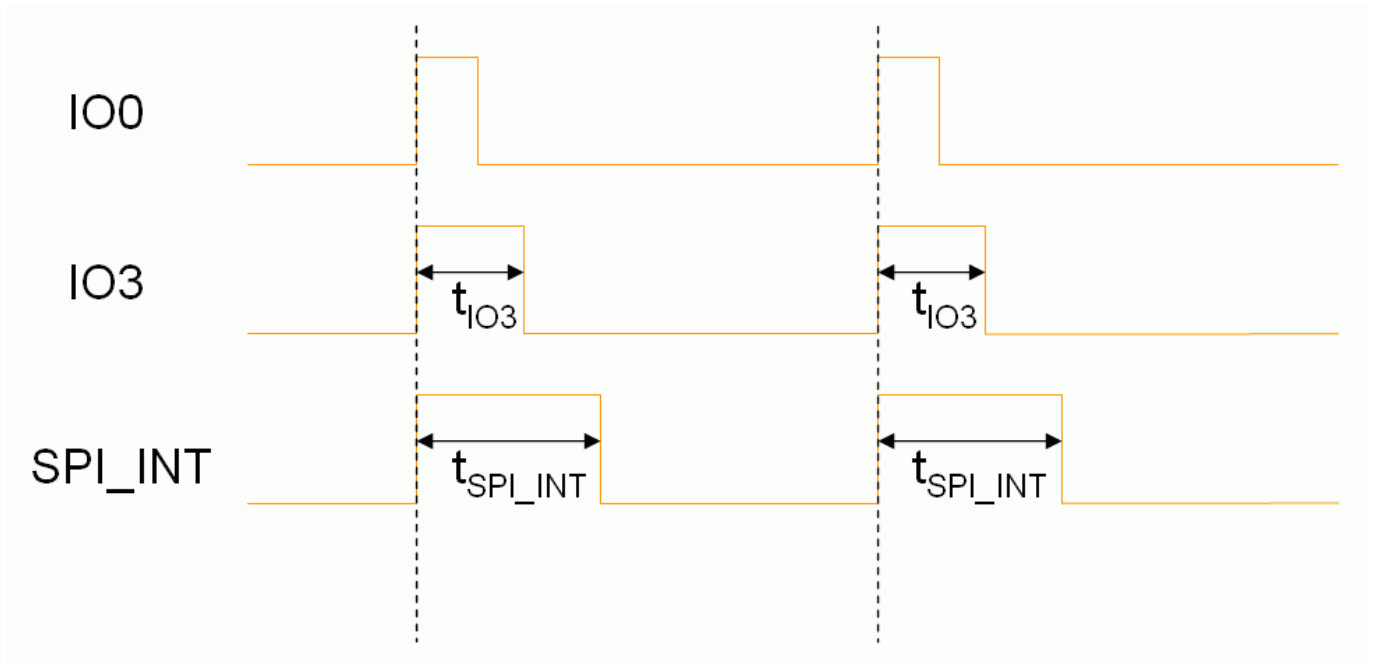

From:
<http://www.mobacon.de/dokuwiki/> - MoBaCon

Permanent link:
<http://www.mobacon.de/dokuwiki/doku.php?id=en:netzer:impulse&rev=1408284613>

Last update: 2025/06/11 20:42

