

Impulse handling with Netzer IO

Netzer is able to generate and capture signals at IO3 and SPI_INT.

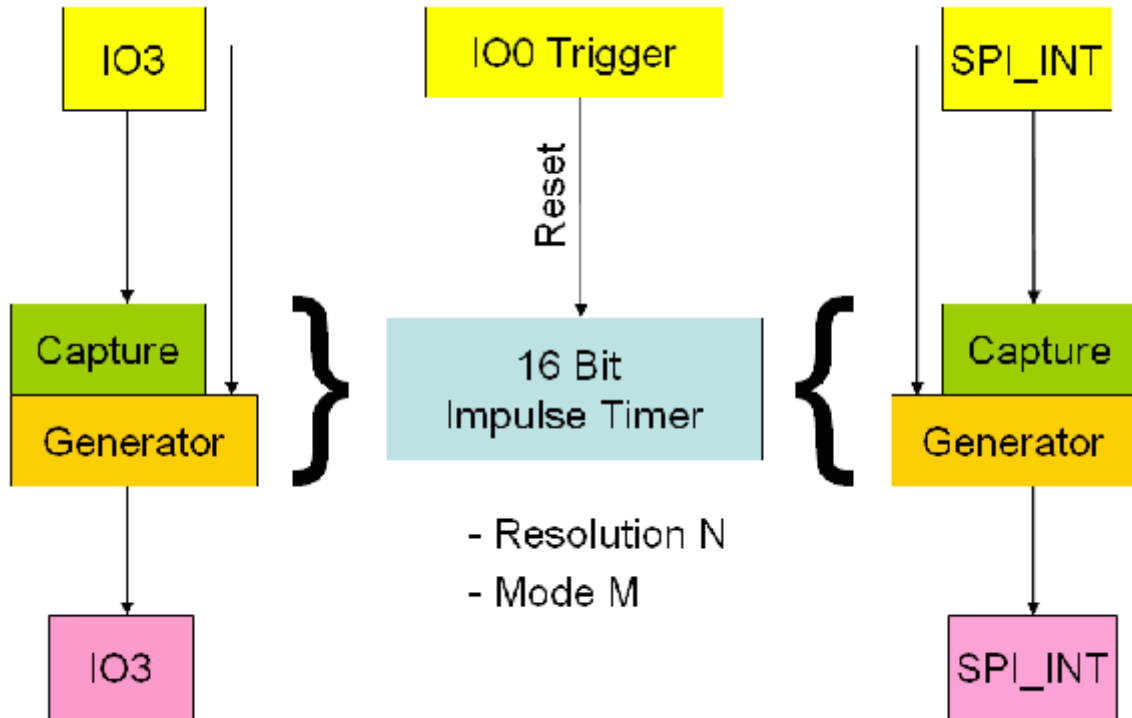

The image shows the structure of the impulse generator/capture.

The impulse module is divided into two modes, the unsynchronized mode and the IO0 synchronized mode. Both, IO3 and SPI_INT, can either work in unsynchronized or in IO0 synchronized mode.

Furthermore a mode M can be configured:

- Continuous mode
- Single
- Triggered by IO0

Resolution N can be either 100ns, 200ns, 400ns or 800ns. All raw values associated with Capture/Generator module must be multiplied by N to get the final time value.

Last but not least channels can be configured for capturing (measuring impulses) or generating impulses.

Unsynchronized mode

The impulse timer is free running in this mode. Changes on IO0 will not reset the impulse timer.

The examples below show both signals IO3 and SPI_INT. Of course impulse module can be configured

to use only one of them.

The examples only show positive logic. Simply invert the signals to get negative logic examples.

Generating impulses in continuous mode

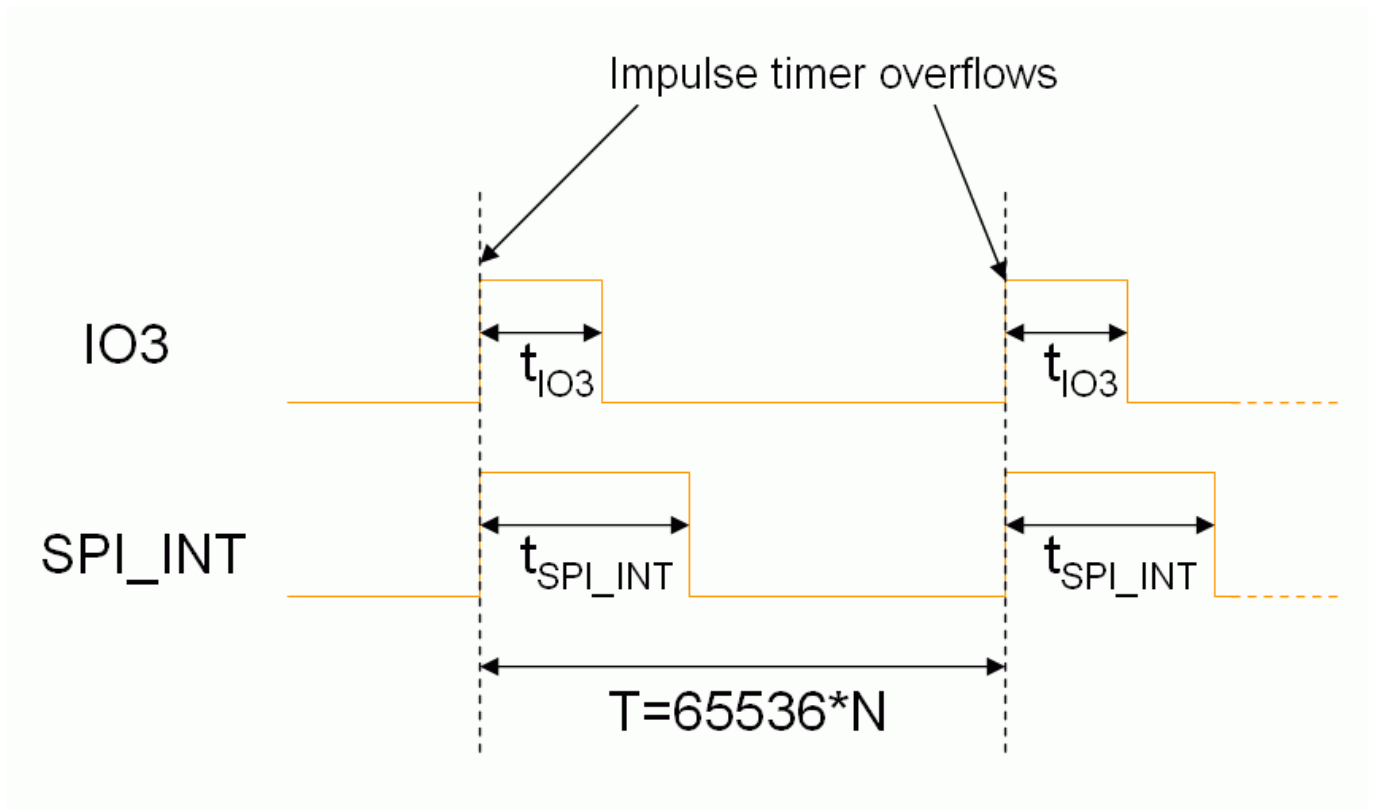

Generating impulses in single mode

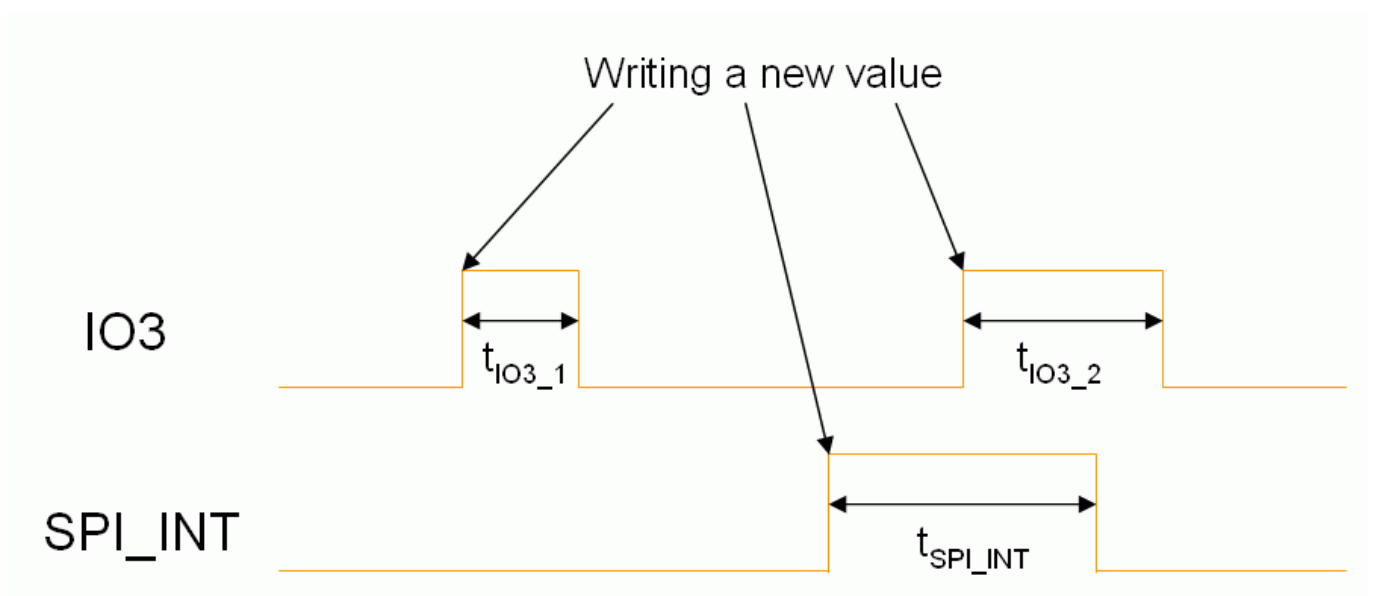

Generating impulses in "Triggered by IO0" mode

This mode shall not be used.

IO0 synchronized mode

The impulse timer is reset (set to 0) by IO0 trigger.

The examples below show the IO0 signal and both signals IO3 and SPI_INT. The impulse module can be configured to use only one of them.

IO0 is configured for rising edges in examples. Simply invert the IO0 signal to get falling edge examples.

The examples only show positive logic. Simply invert the signals to get negative logic examples.

Generating impulses in continuous mode

This mode shall not be used.

Generating impulses in single mode

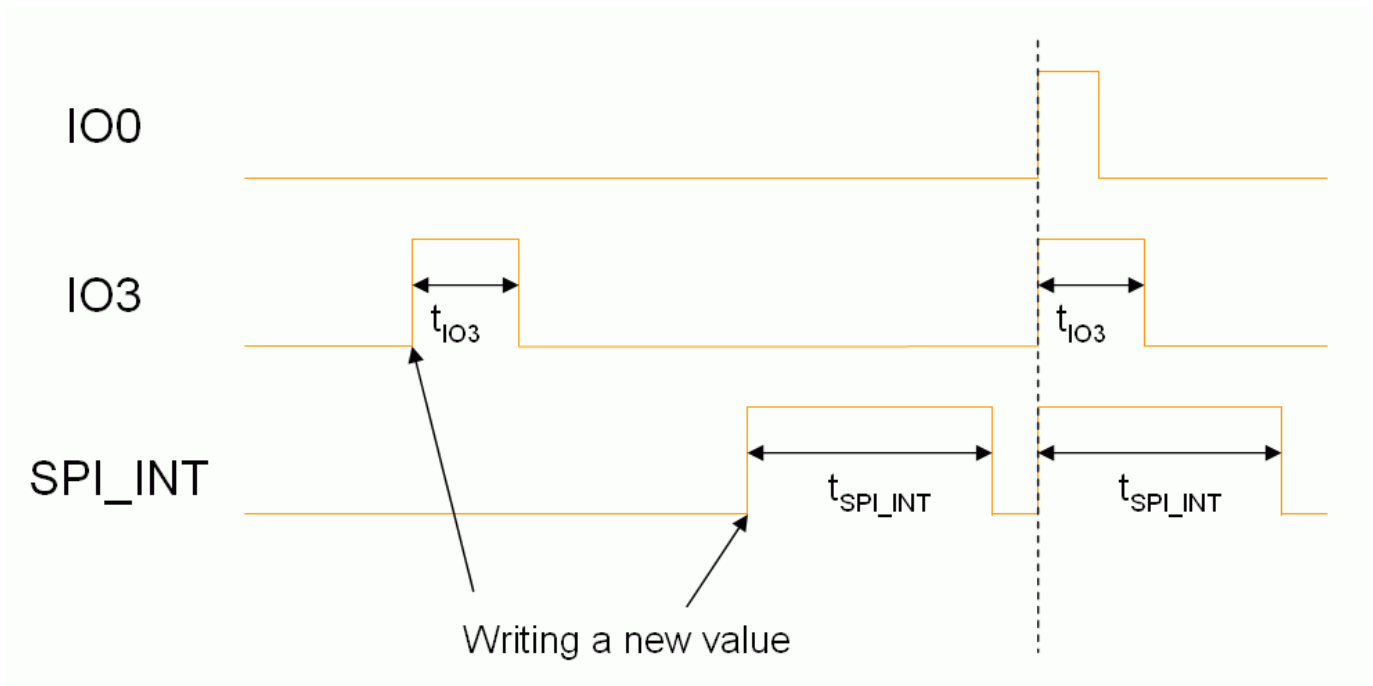

Generating impulses in "Triggered by IO0" mode

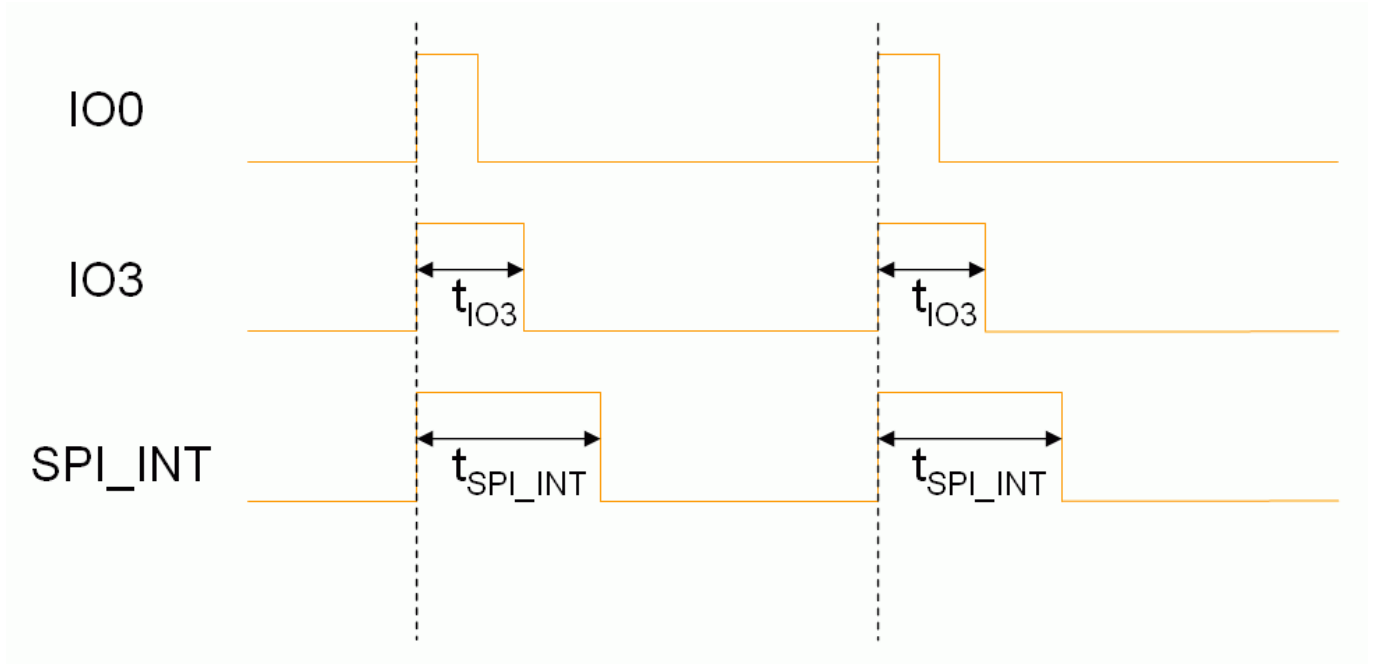

From: <http://www.mobacon.de/dokuwiki/> - MoBaCon

Permanent link: <http://www.mobacon.de/dokuwiki/doku.php?id=en:netzer:impulse&rev=1408205699>

Last update: 2025/06/11 20:42

